

LIQUID SOAP DISPENSER PP 102

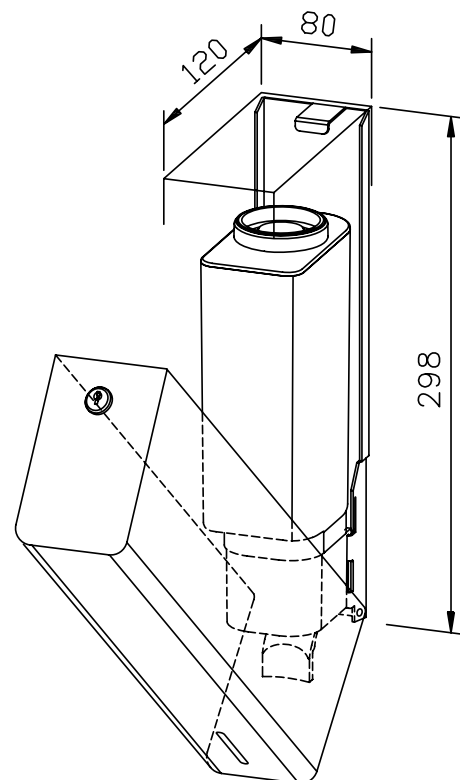

80 x 298 x 120 mm
1100 ml fixed soap tank

- Full metal housing in robust, easy-to-clean stainless steel AISI 316L, satin finished, rounded vertical corners.
- With fixed soap tank, capacity 1100 ml.
- Inspection slot to indicate refill level.
- Housing swings down for refilling.
- Dispenser with drip-free, single-hand pull-operation soap pump.
- Dispenser lockable with cylinder lock, fitted on the top.
- Easy to clean due to optimum accessibility.
- Simple mounting: line up with tiles and fasten with 4 screws.

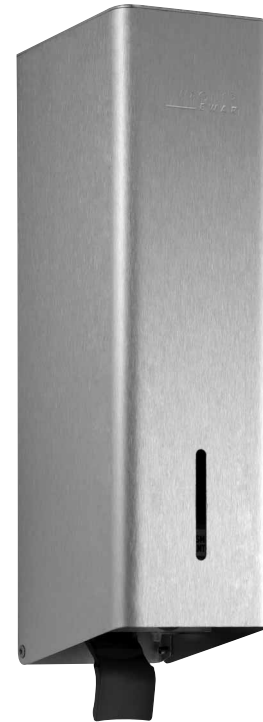

Suggested text for specifications:

Liquid soap dispenser in stainless steel AISI 316L for surface mounting, satin finished, lockable with cylinder lock. Full metal housing with rounded vertical corners.

Dimensions 80 x 298 x 120 mm;
with 1100 ml fixed soap tank; includes
mounting components.

Article No. PP 102

Available surfaces	Ident-No.
satin finished (standard)	727 339
highly polished	731 339
(coloured) plastic powder - coating	728 339

Ernst Wagner GmbH & Co. KG

Ernst-Abbe-Straße 21 · D-72770 Reutlingen · Tel.: +49712151539-0 · Fax: -20
info@wagner-ewar.de · www.wagner-ewar.de

WAGNER
EWAR